



## DRAWING INSTRUMENTS AND THEIR USES

### Introduction :-

Drawing instruments are used to prepare drawings easily and accurately. The accuracy of the drawings depends largely on the quality of instruments. With instruments of good quality, desirable accuracy can be attained with ease. It is, therefore, essential to procure instruments of as superior quality as possible.

### Drawing instruments -

1. Drawing board
2. T-square
3. Set-squares -  $45^\circ$  and  $30^\circ-60^\circ$
4. Drawing instrument box containing:

<ul style="list-style-type: none"> <li>(i) large size compass with inter-changeable pencil</li> <li>(ii) lengthening bar</li> <li>(iii) small bow compass</li> <li>(iv) large-size divider</li> </ul>	<ul style="list-style-type: none"> <li>(v) small bow divider</li> <li>(vi) small bow ink-pen</li> <li>(vii) linking pen</li> </ul>
---	--
5. Scales
6. Protractor
7. French Curves
8. Drawing Papers
9. Drawing pencils
10. Sand-paper block
11. Eraser
12. Drawing pins, clip or adhesive tapes
13. Duster
14. Drafting machine
15. Roll-n-draw



Drawing board -

Drawing board is rectangular shape and is made of strips of well-seasoned soft wood about 25 mm thick. It is cleated at the back by two battens to prevent warping. one of the edges of the board is used as the working edge, on which T-square is made to slide.

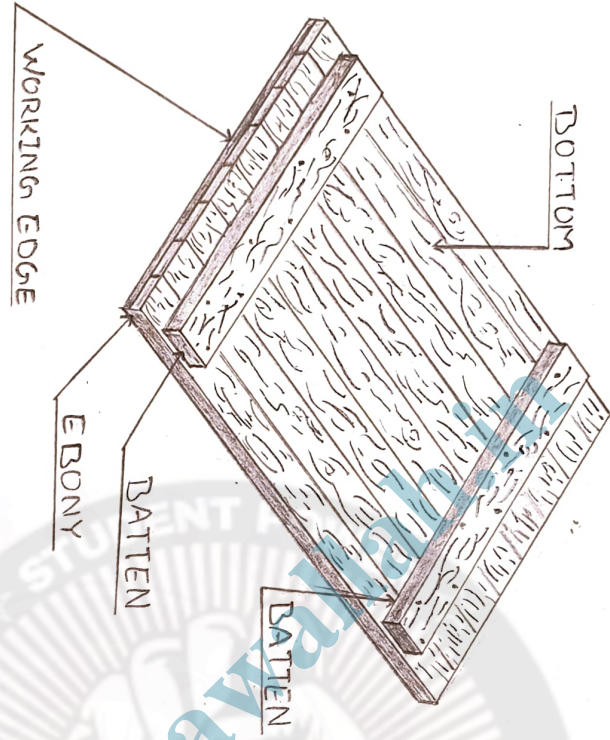

TABLE 11  
Size of Drawing boards

Designation	Size (mm)
B0	1000 x 1500
B1	700 x 1000
B2	500 x 700
B3	350 x 500

2. T. SQUARE

A T-square is made up of hard-quality wood. It consists of two parts - the stock and the blade - joined together at right angles to each other by means of screws and point pins. The stock is placed adjoining the working edge of the board and is made to slide on it as and when required.



3. SET-SQUARES

The set-squares are made of wood, tin, celluloid or plastic. Those made of transparent Celluloid or plastic are commonly used as they retain their shape and accuracy for a long time. Two forms of set-squares are in general use. A set square is triangular in shape with one of the angle as right angle.

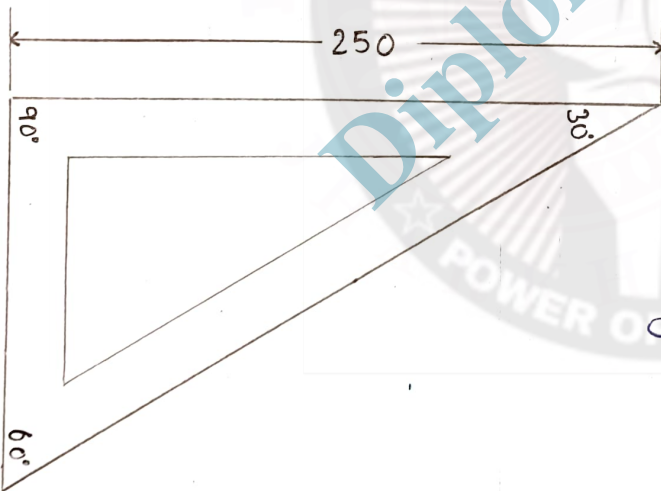
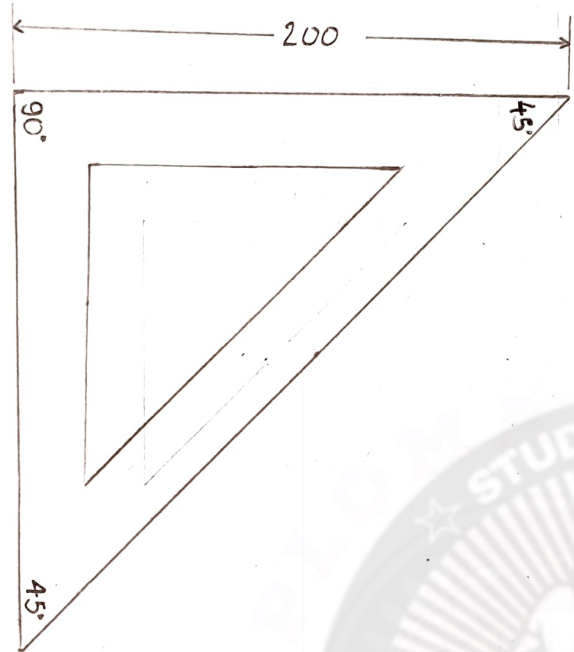
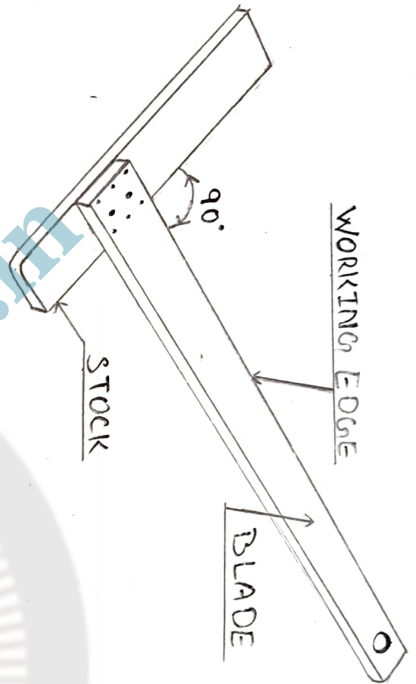



Drawing Instrument Box

Large-size compass with interchangeable pencil and pen legs.  
 The compass is used for drawing circles and arcs of circles. It consists of two legs hinged together at its upper end. A pointed needle is fitted at the lower end of one leg, while a pencil lead is inserted at the end of the other leg. It can be interchanged with a similar piece containing an inking pen.

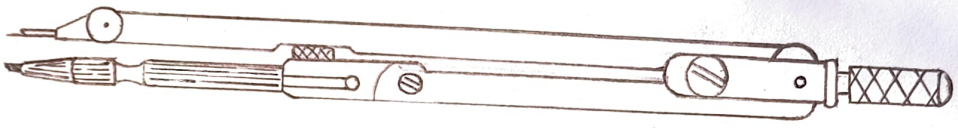

LARGE-SIZE COMPASS WITH INTERCHANGEABLE PENCIL AND PEN LEGS

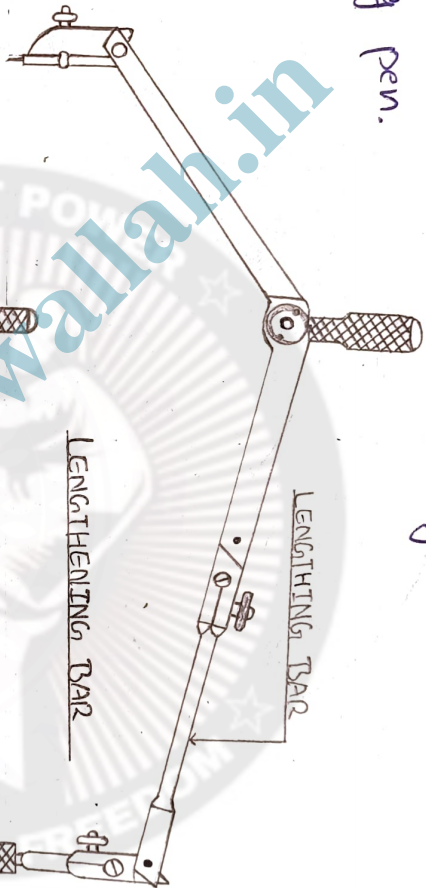

SMALL ROW DIVIDER

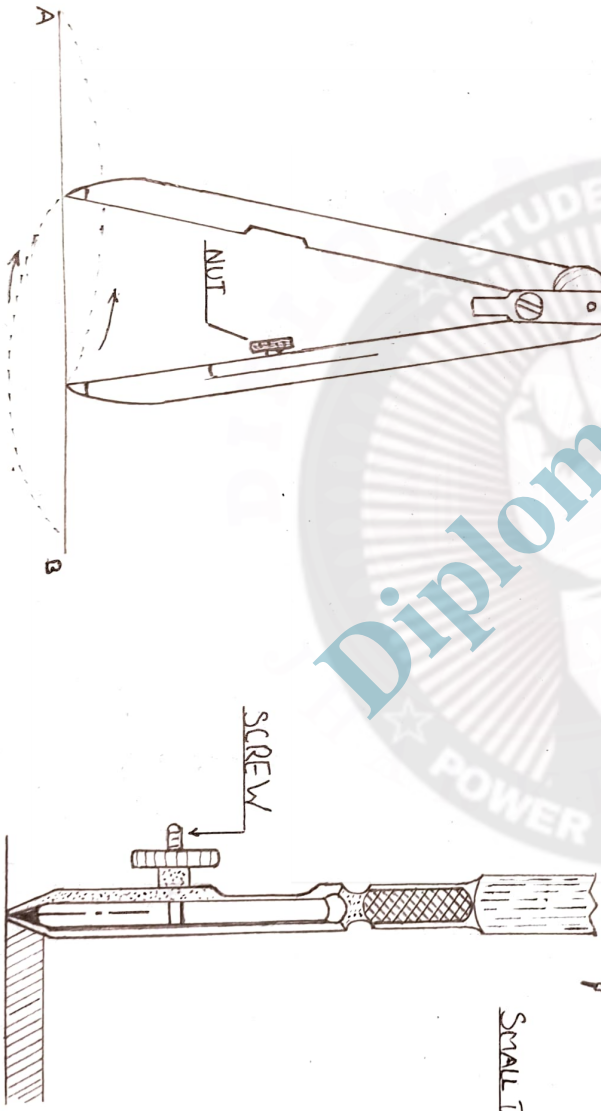

INKING PEN

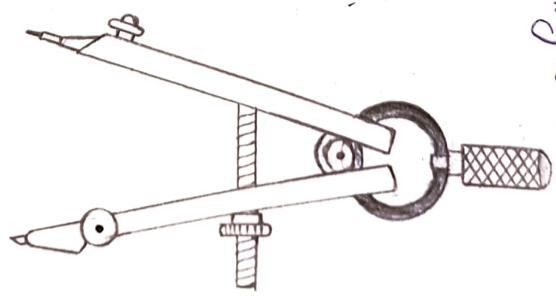

SMALL ROW COMPASS



Scale

Scales are made of wood, steel, celluloid or plastic or card board. stainless-steel scales are more durable. Scales may be flat or of triangular cross-section. 15 cm long and 2 cm wide or 30 cm long and 3 cm wide flat scales are common use.



6. Protractor

Protractor is made of wood, tin or celluloid. Protractors of transparent celluloid are in common use. They are flat and circular or semi-circular in shape.

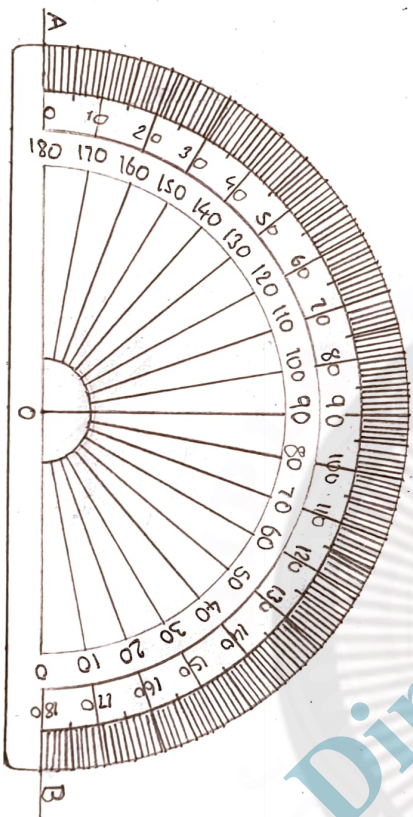



FRENCH CURVES

French Curves are made of wood, plastic or celluloid. They are made in various shapes, one of which shown in figure below. French curves are used for drawing curves which cannot be drawn with a compass.

8. DRAWING PAPERS

Drawing papers are available in many varieties. For ordinary pencil-drawings, the paper selected should be thick, tough and strong. Good quality of paper with smooth surface should be selected for drawings which are to be inked and preserved for a long time. The standard sizes of drawing papers -





DRAWING PENCIL

The accuracy and appearance of a drawing depend very largely on the quality of the pencil used. Finishing of a drawing should be made with H or 2H pencil. using it very rightly, so that the lines are faint and unnecessary or extra lines can be easily erased.



(a)



(b)  
Chisel edge

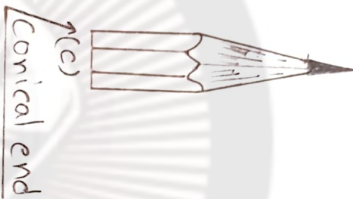

(c)  
Conical end

10. DRAWING PINS, CLIPS OR ADHESIVE TAPES

These are used to fix the drawing paper on the drawing board. The needle part of the pin is generally made of steel, while the head may be of plated mild steel or brass. clips or adhesive tapes are often used instead of the pins.



(a)



(b)



(c)



ND-PAPER BLOCK

IT consists of a wooden block about 150mm x 50mm x 12mm thick with a piece of sand-paper pasted or nailed on about half of its length. It is used for sharpening the pencil lead every few minutes.

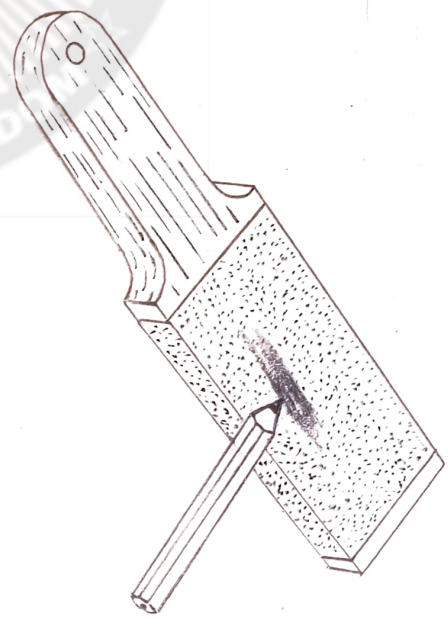

12. DRAFTING MACHINE

The uses of the T-square, set-squares, scale and the protractor are combined in the drafting machine. Its one end is clamped by means of a screw, to the distant longer edge of the drawing board. At its other end, an adjustable head having protractors marking is fitted. Two blade of transparent celloloid accurately set at right angles to each other are attached to the head.

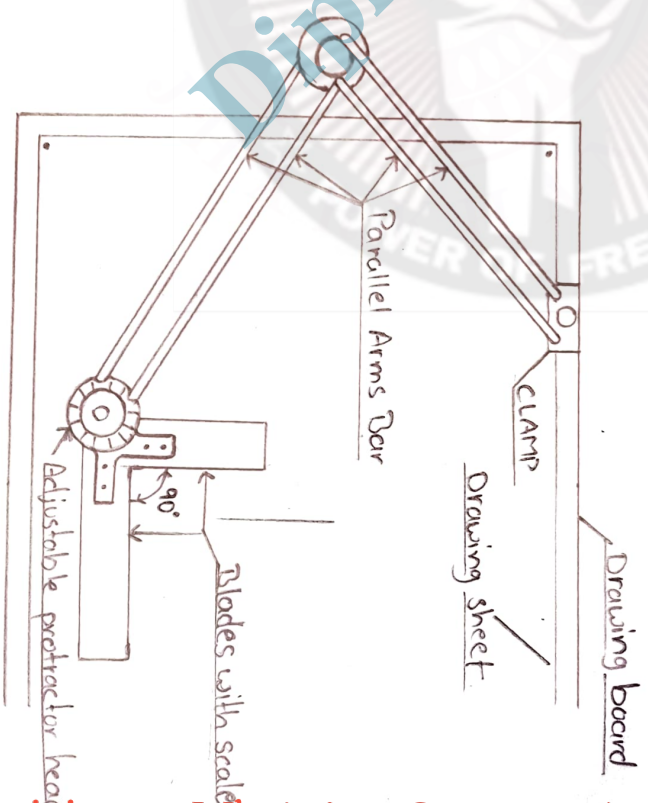



13. ROLL-N-DRAW

It consists of graduated roller, scale of 16 or 30 centimeter and protractor. It is ideal for drawing vertical lines, horizontal lines, parallel lines, angles and circles.

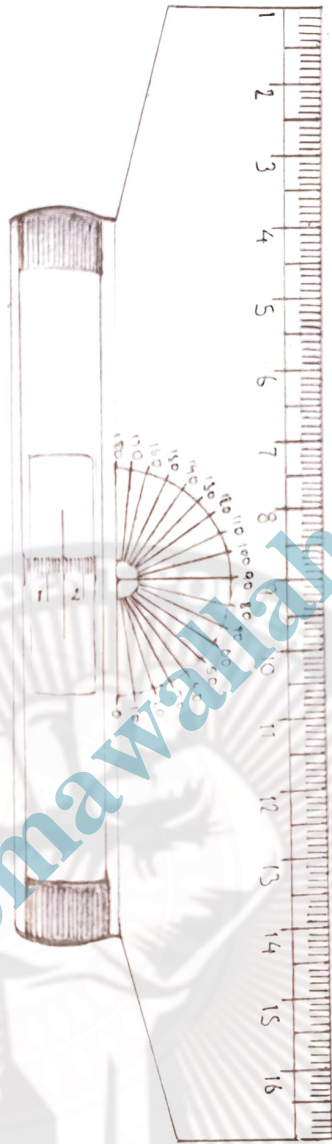

DiplomaWala.in



LETTERING

- 1) single stroke Capital (Vertical)
- 2) single stroke Capital (Inclined)
- 3) single stroke Small (Vertical)
- 4) single stroke Small (Inclined)

Height - 3.5 mm  
 Ratio - 7:4

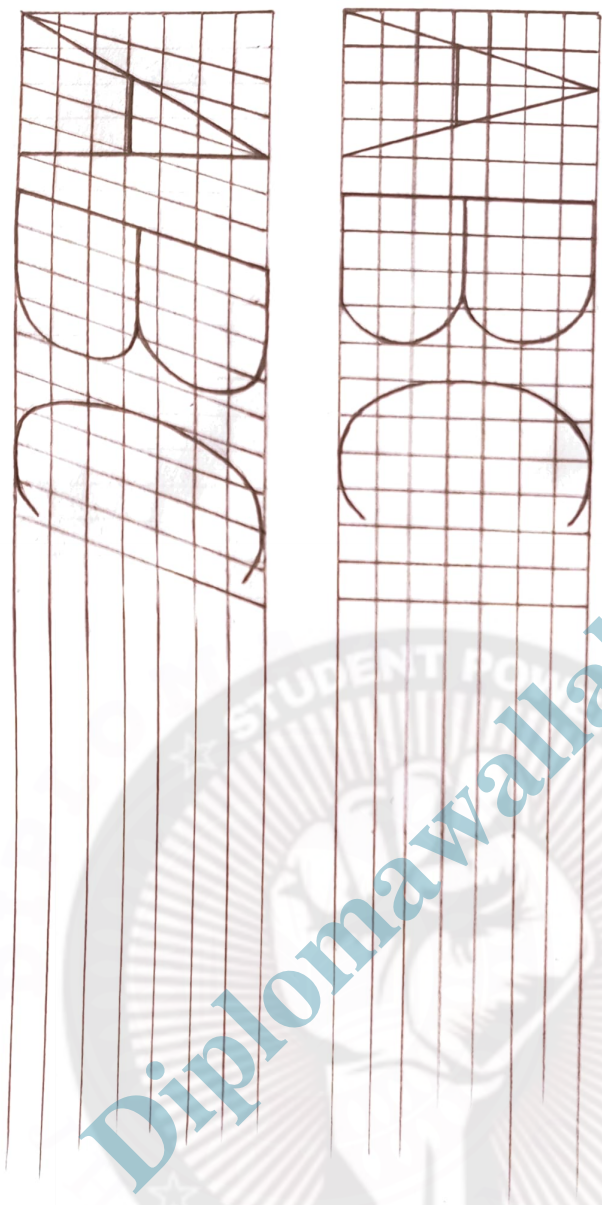

Formula for Gapping -  
 $\frac{10}{14} \times H$  for sentence  
 $\frac{6}{14} \times H$  for words

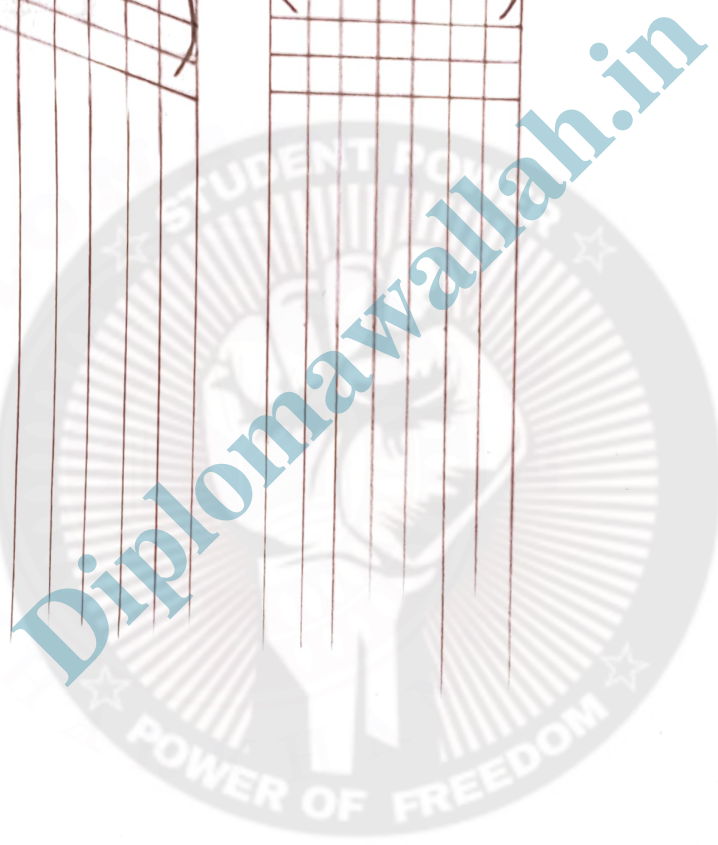

# SCALES

Scale :- It is used to measure or draw the linear dimension.

Representative fraction (R.F.) / scale ratio - It is the ratio of drawing dimensions to the given dimension of the object.

$$\left( R.F. = \frac{DD}{GD} \right)$$

R.F. > 1 = Enlarge scale

R.F. = 1 = Full scale

R.F. < 1 = Reduced scale

## Types of scale -

1. Plain scale
2. Diagonal scale
3. Comparative scale
4. Vernier scale
5. Scale of chords

Height of plane scale -

Minimum 6.5 mm, and

Maximum 10 mm.

Diplomawallah.in

Problem 4.1 → Construct a scale of 1:4 to show centimetres and long enough to measure upto 5 decimetres.

Given ⇒ 1) R.F. =  $\frac{1}{4}$

2) unit to be shown = 1cm, 1dm, 3.7 dm

3) Maximum length = 5dm

4) Length of scale = R.F. × maximum length

$$= \frac{1}{4} \times 5 \text{ dm} = \frac{1}{4} \times 5 \times 10$$
$$= 12.5 \text{ cm}$$

$$[ 1 \text{ dm} = 10 \text{ cm} ]$$

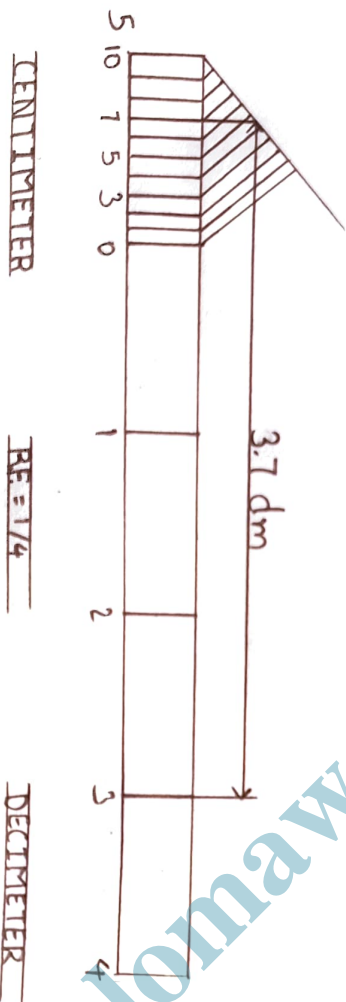

CENTIMETER

R.F. =  $\frac{1}{4}$

DECIMETER

Problem 4.5 → Construct a scale of R.F. =  $1/84480$  to show miles and forlongs and long enough to measure upto 6 miles.

- Given ⇒
- 1) R.F. =  $1/84480$
  - 2) unit to be shown = 1 mile, 1 forlong, 4m 3flo
  - 3) length of scale = R.F. × maximum length

$$\begin{aligned}
 &= 1/84480 \times 6 \text{ mile} \\
 &= 1/84480 \times 6 \times 63360 \text{ inches} \\
 &= 4.5 \text{ inch}
 \end{aligned}$$

$$\left[ \begin{array}{l} 1 \text{ mile} = 63360 \text{ inches} \\ 1 \text{ mile} = 8 \text{ forlong} \end{array} \right]$$

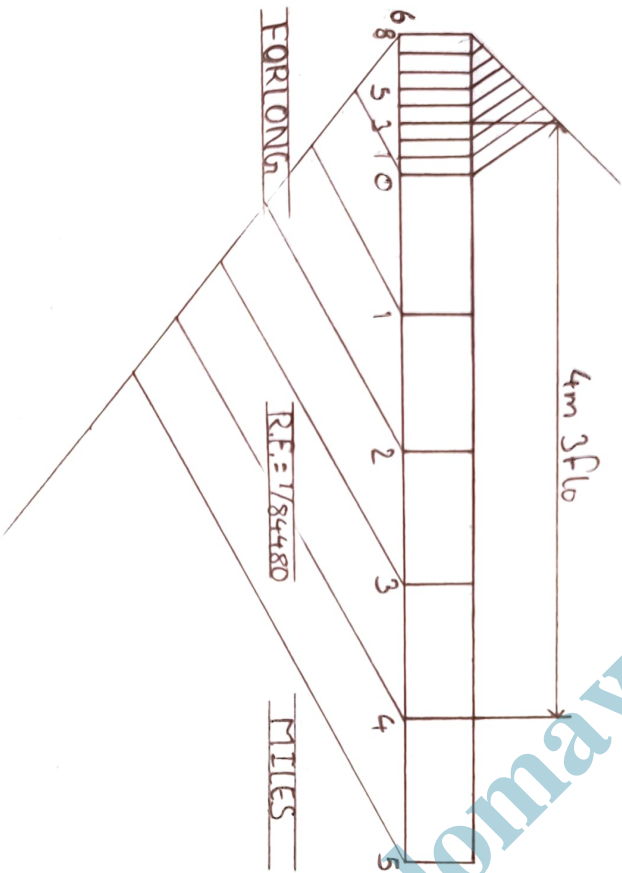

Problem 4.6 → Construct a diagonal scale of 3:200 i.e.  $1:66\frac{2}{3}$  showing metres, decimetres and centimetres and to measure upto 6 metres.

Given ⇒ 1) R.F. =  $3/200$

- 2) unit to be shown = 1m, 1dm, 1cm, 3.78cm
- 3) maximum length = 6m
- 4) length of scale = R.F. × maximum length

$$= \frac{3}{200} \times 6m = \frac{3}{200} \times 6 \times 100 \text{ cm} = 9 \text{ cm}$$

$$\left[ \begin{array}{l} 1 \text{ metre} = 10 \text{ dm} \\ 1 \text{ dm} = 10 \text{ cm} \end{array} \right]$$

Diplomawallah.in

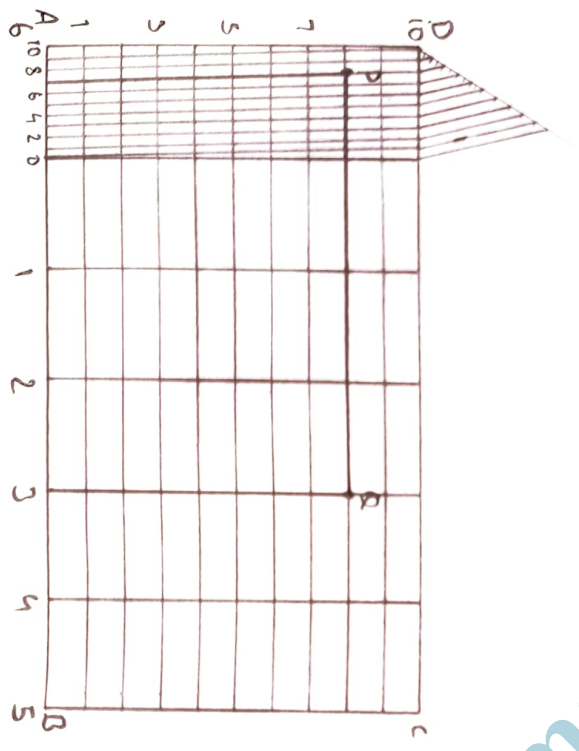

DECIMETRES      RF = 3/200      METRES

Problem 4.8 → Draw a diagonal scale of 1:25, showing centimetres and millimetres.

Given ⇒ 1) R.F. =  $\frac{1}{25}$

2) maximum length = 20 cm

3) unit to be shown = 1 cm, 1 mm, 13.4 cm

4) length of scale = R.F. × maximum length

$$= \frac{1}{25} \times 20 = 8 \text{ cm}$$

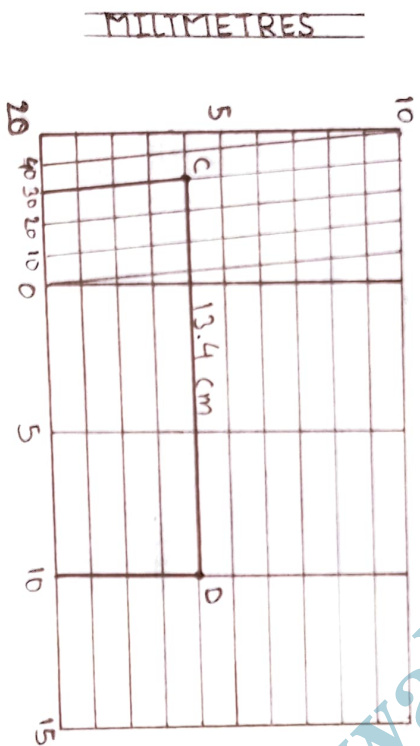

R.F. =  $\frac{1}{25}$

CENTIMETRES

## CURVE & CONIC SECTION

Conics — The section obtained by the intersection of a right circular cone formed by a plane in the different positions relative to the axis of the cone are called conics.

Ellipse — When the section plane is applied to the axis and cut all the generators of one side of the apex, the section is the ellipse.

Parabola — When the section plane is inclined to the axis and is parallel to one of the generators, the section plane is a parabola.

Hyperbola — The hyperbola is a plane having two separate parts or branches formed when two planes that point towards one another are extended. The intersection by a plane, that is parallel to the axis.

Eccentricity — The ratio of the distance of point from the focus to distance to the point to the directrix is Eccentricity.

- 1) Ellipse  $e < 1$
- 2) Parabola  $e = 1$
- 3) Hyperbola  $e > 1$

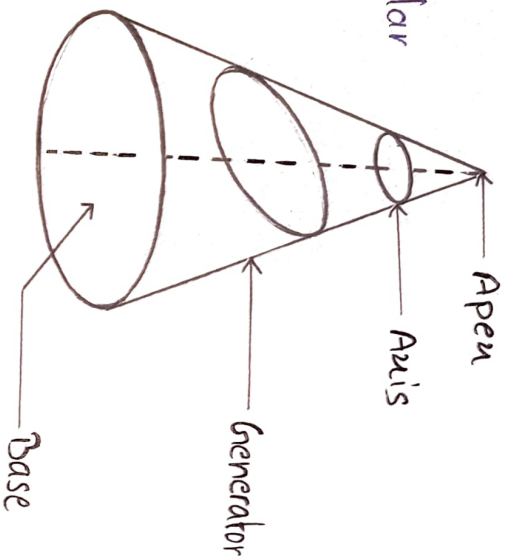

To construct an ellipse when the distance of the focus from the directrix is ~~2/3~~ equal to some and eccentricity is  $2/3$ .

- Given  $\Rightarrow$
- 1) Draw ellipse by directrix method
  - 2) Distance of focus from directrix = 50mm
  - 3)  $e = 2/3$
  - 4) Draw TANGENTS & NORMAL line.

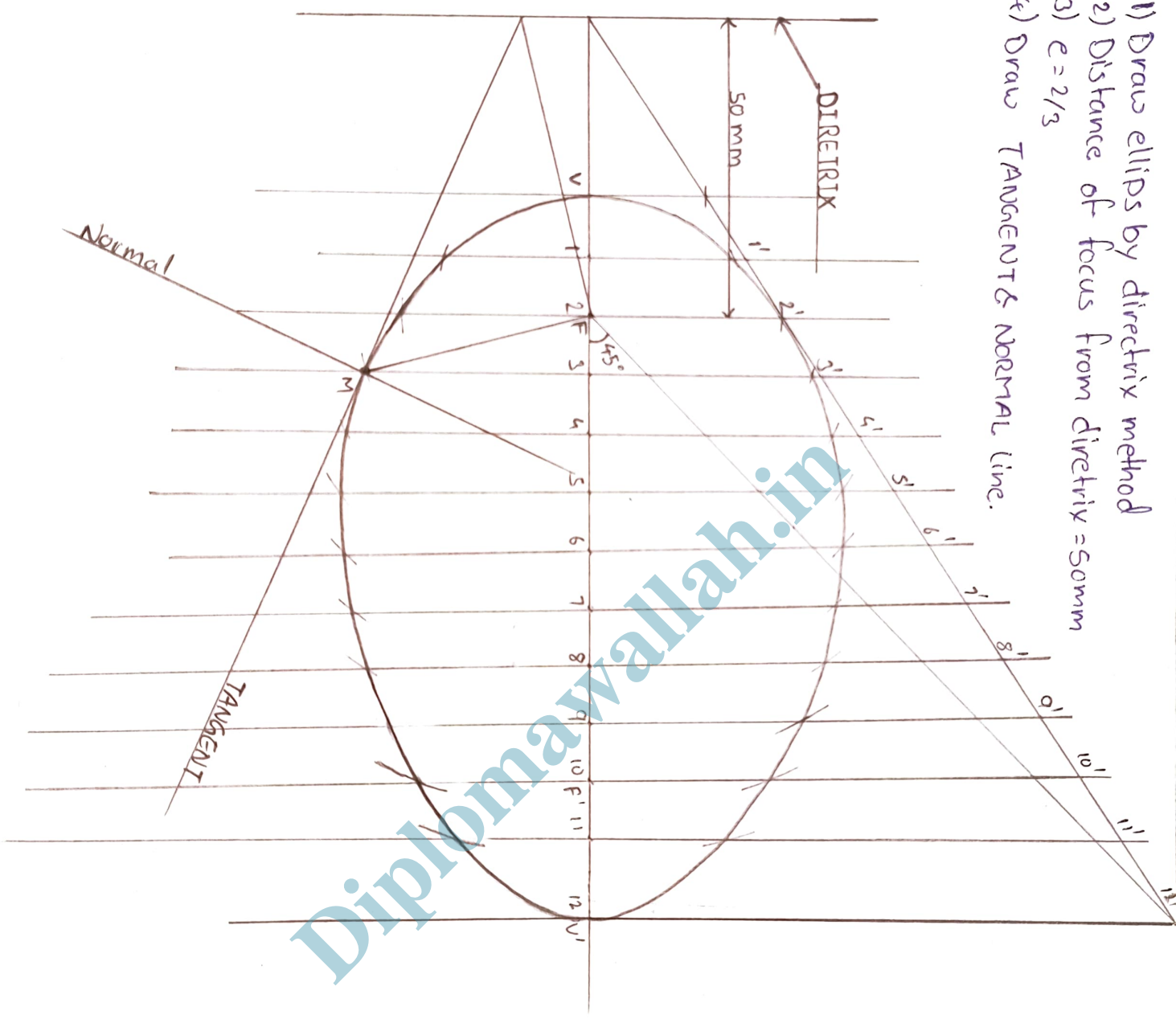

# Ellipse

Arc of circle method -

Q Draw an ellipse of major axis 100 mm and minor axis 50 mm by arc of circle method. Also draw the tangent and normal line at any point on the curve.

Given  $\Rightarrow$  Major axis = 100 mm  
minor axis = 50 mm

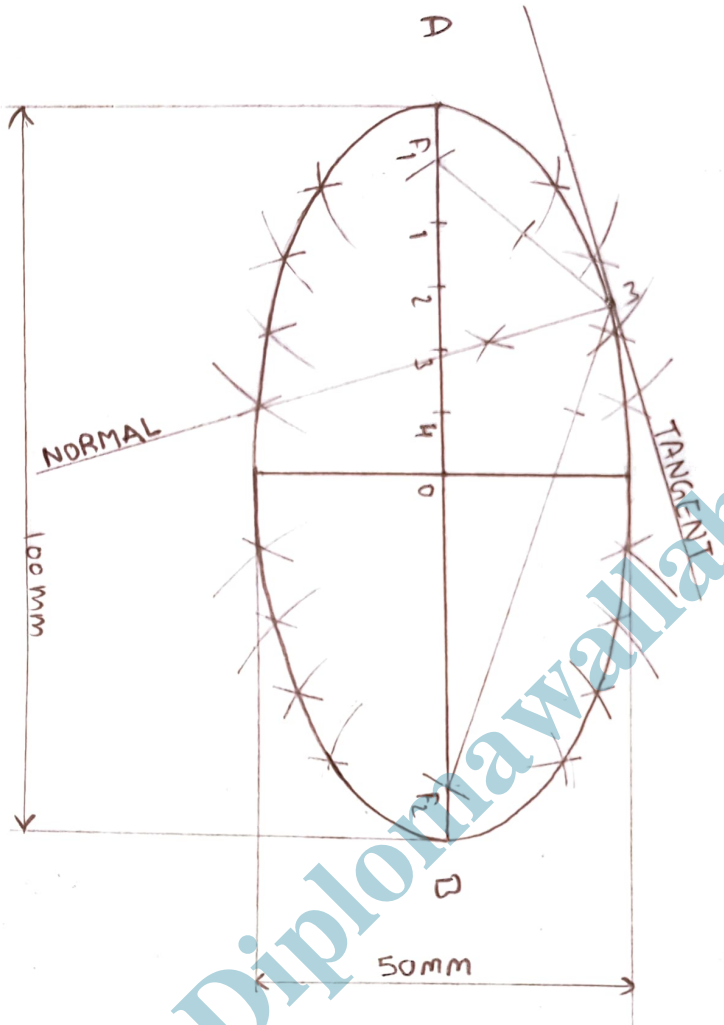

Diplomawallah.in

Problem 6.11 → To construct a parabola given the base and the axis.

Rectangular method

- Given ⇒
- 1) Base = 100 mm
  - 2) Height = 50 mm
  - 3) Draw Tangent & Normal line.

Problem 6.15 → A Point is 30mm and 50 mm respectively from two straight lines which at right angle to each other. Draw a rectangular hyperbola from P with in 10mm distance from each line.

Rectangular method

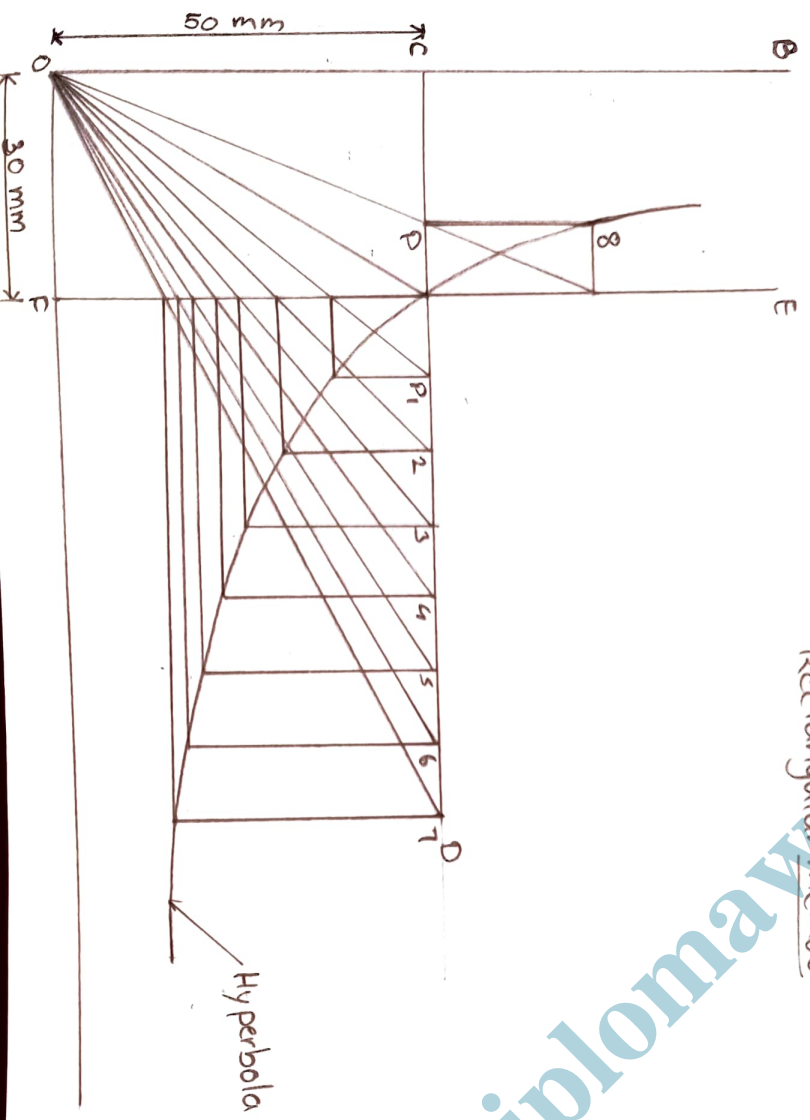
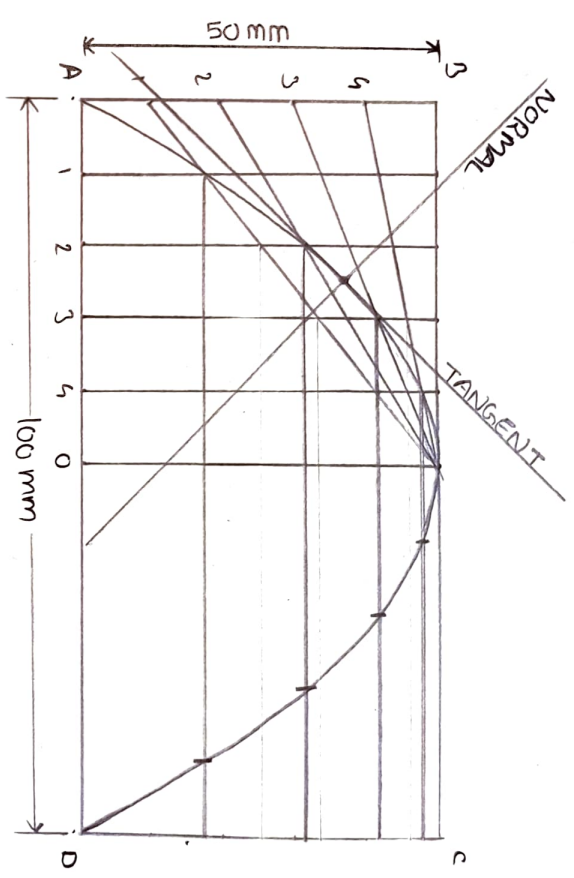

# Orthographic Projection

3D - 2D view

- 1) First Angle method
- 2) Second Angle method
- 3) Third Angle method
- 4) Fourth Angle method

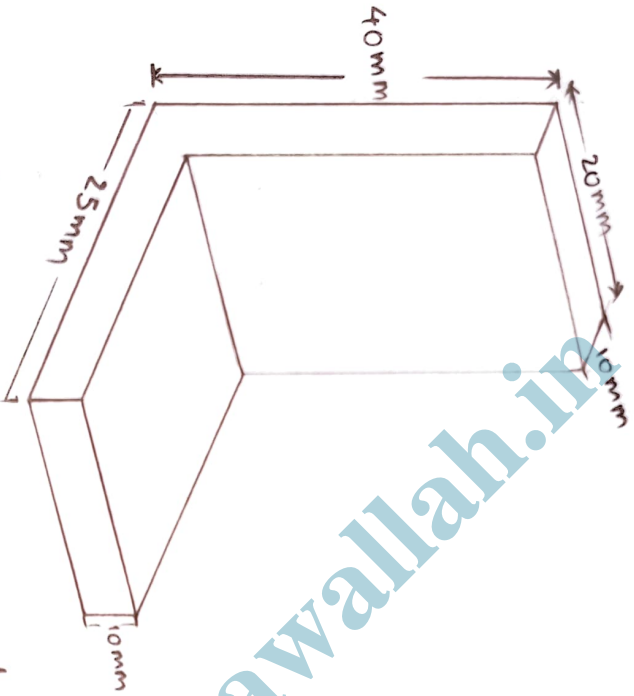

1st angle method

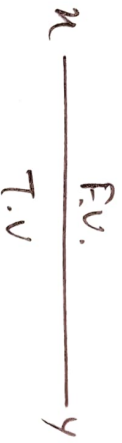

3rd angle method

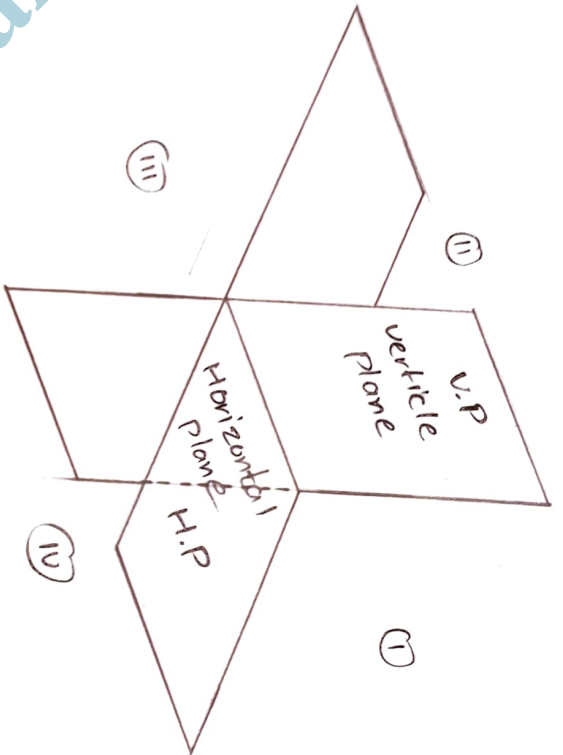

## Projection of Point

- Projection of points -

F.V & T.V only

$$\begin{array}{c} x \\ \hline \frac{\text{F.V. } (a')}{\text{T.V. } (a)} \\ \hline y \end{array}$$

→ 1st quadrant -

Point is above H.P and in front of V.P

→ 2nd Quadrant -

Point is above H.P and behind V.P

→ 3rd Quadrant -

Point is below H.P and behind V.P

→ 4th quadrant -

Point is below H.P and in front of V.P

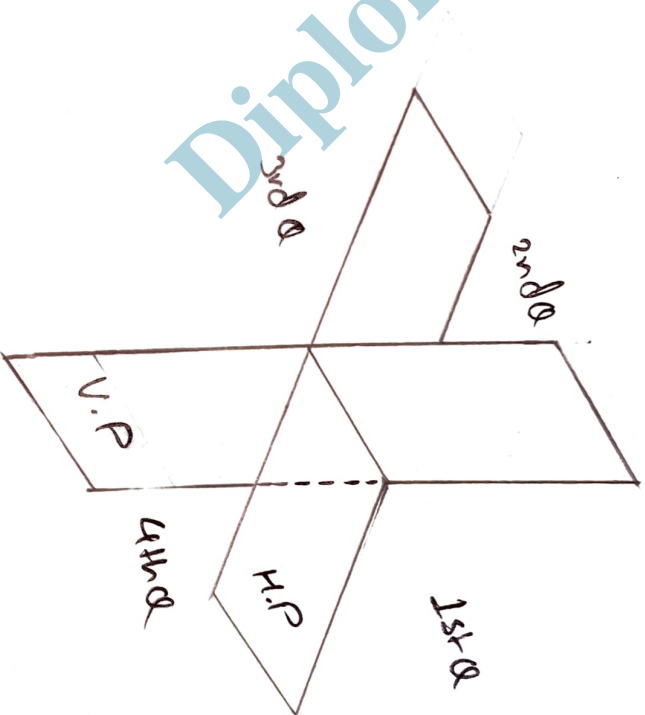

- Q 1) The point A is 40 mm above H.P and 50 mm in front of V.P. Draw its projection.
- Q 2) The point A is 40 mm above H.P and 50 mm behind V.P. Draw its projection.
- Q 3) The point A is 40 mm below H.P and 50 mm behind V.P. Draw its projection.

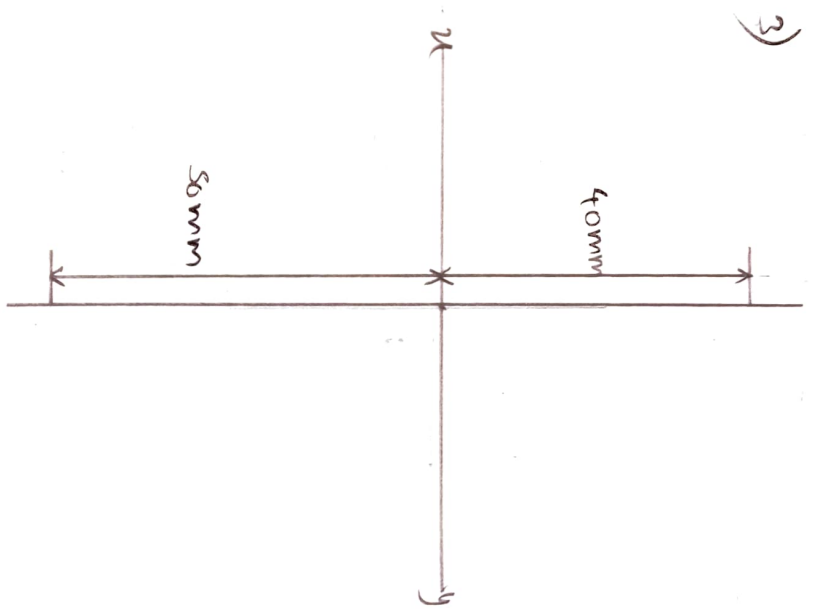
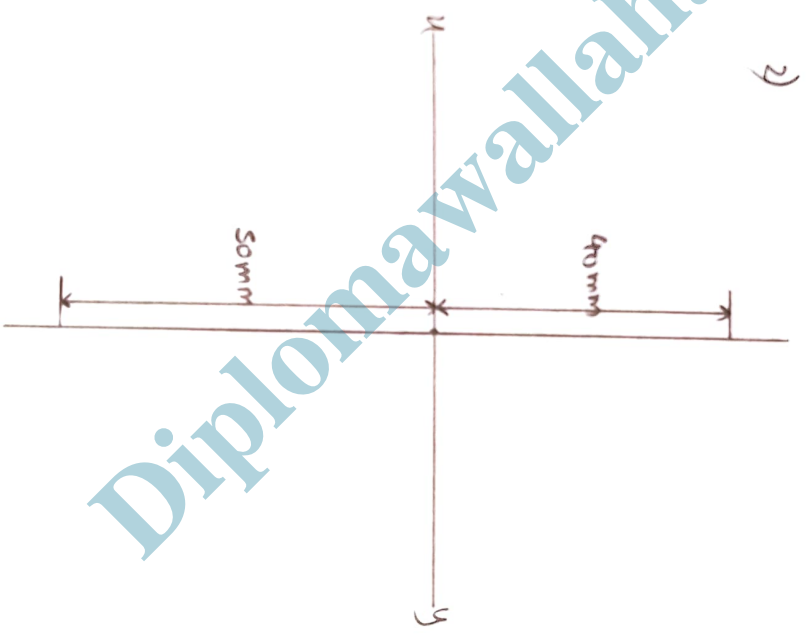
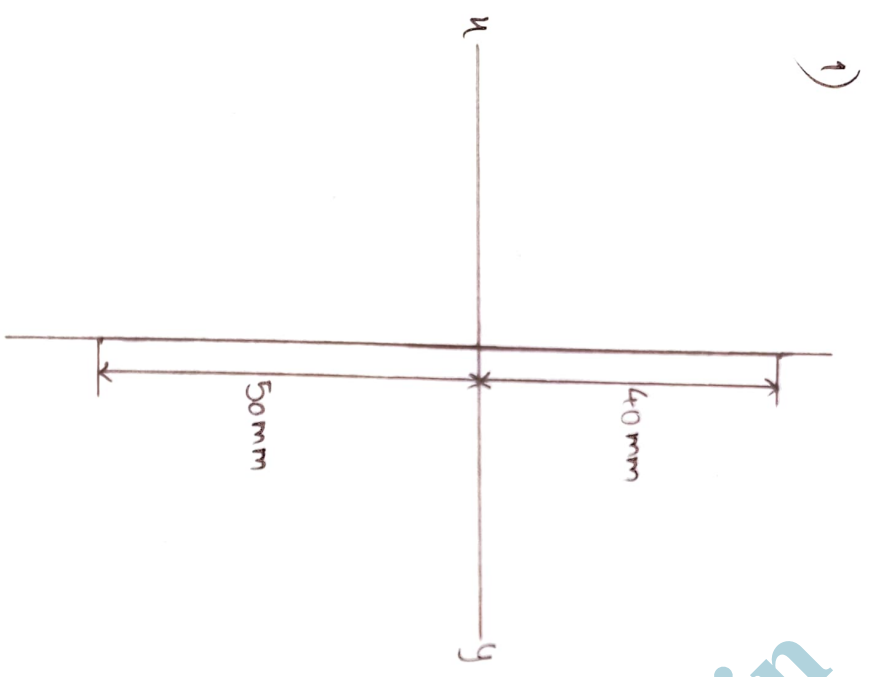

Diplomawallah.in

# Projection of straight line

1) line is parallel to both H.P and V.P.

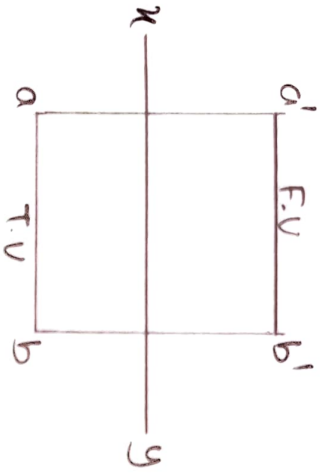

2) line is on the both H.P and V.P.



3) line is perpendicular to H.P and parallel to V.P.

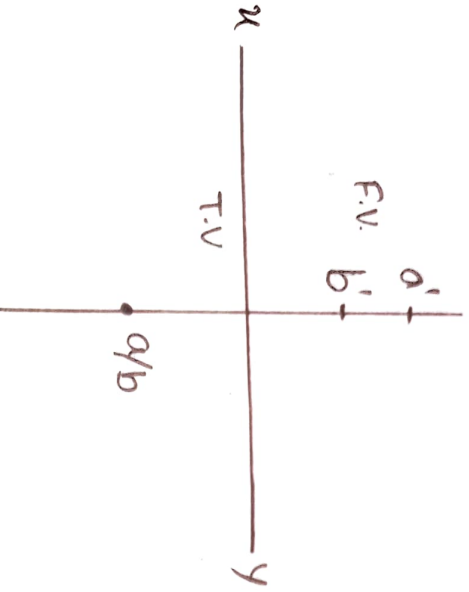

4) line is perpendicular to V.P and parallel to H.P.

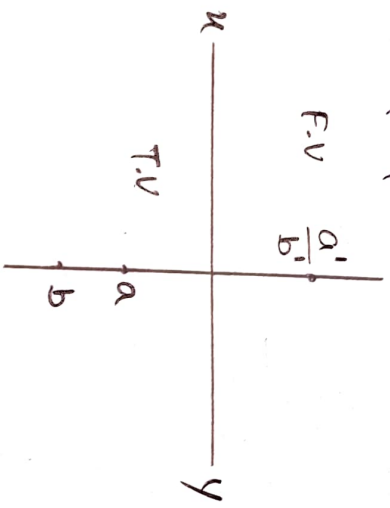

5) line is inclined to H.P and parallel to V.P.

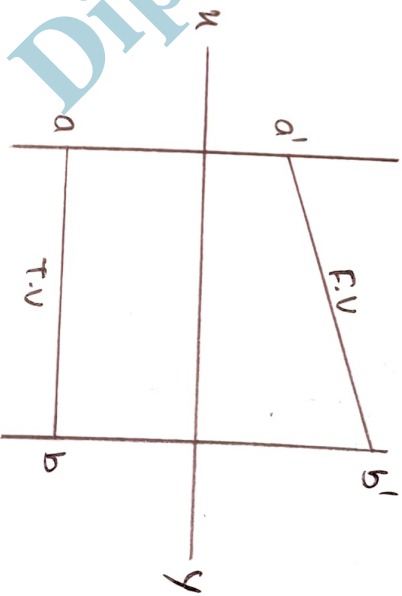

6) line is inclined to H.P and in the V.P.

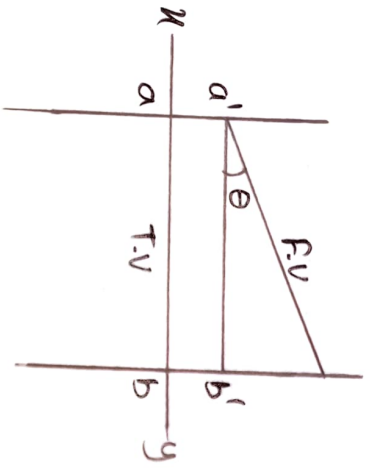

7) line is parallel to H.P and inclined to V.P.

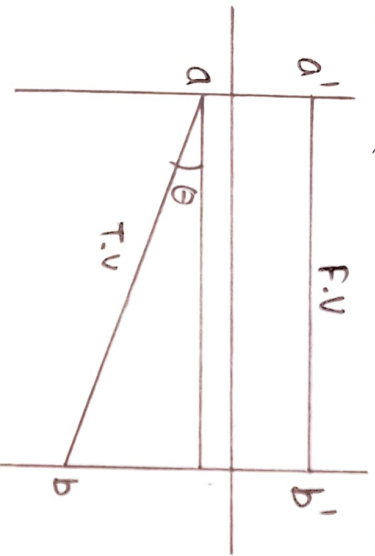

8) line is in H.P and inclined to V.P.

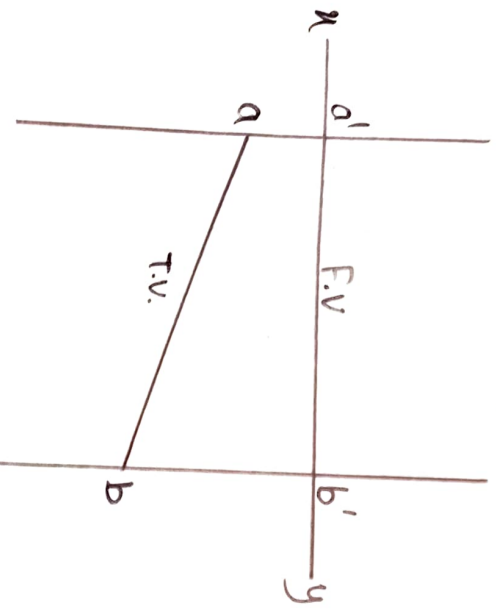

- Angle of F.V =  $\alpha$
- Angle of T.V =  $\beta$
- Reference line above angle =  $\Theta$
- Reference line below angle =  $\Phi$

\* True angle is always bigger than T.V, F.V.

Q A line AB, 90mm long is inclined at  $30^\circ$  to the H.P. Its end A is 12mm above the H.P. and 20mm in front of the V.P. Its front view measures 65mm. Draw the top view of AB and determine its inclination with the V.P.

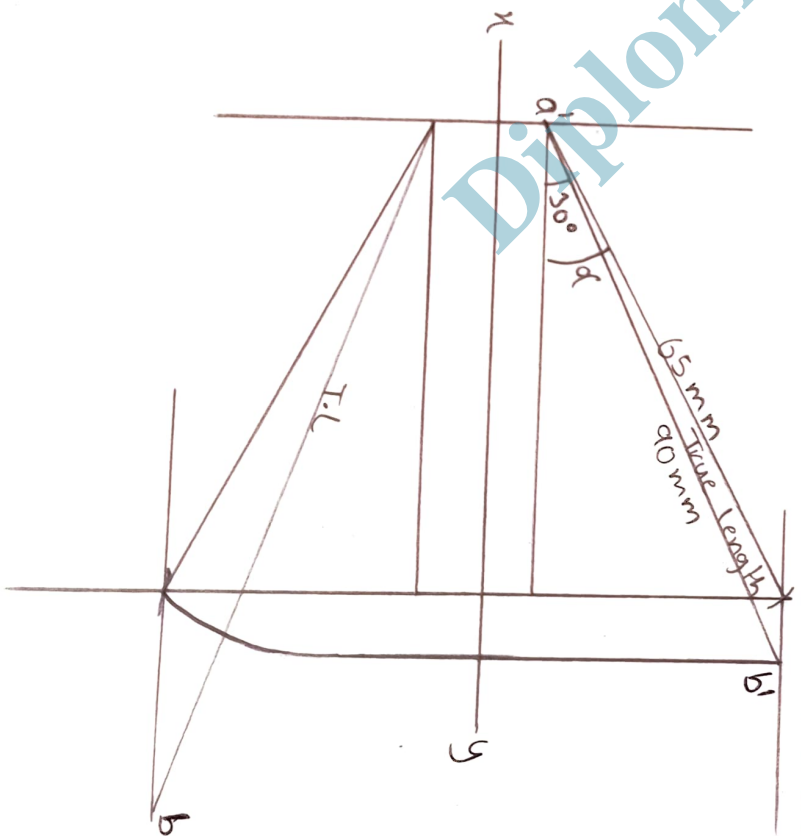

Conversion of Pictorial view into Orthographics

P-17.17

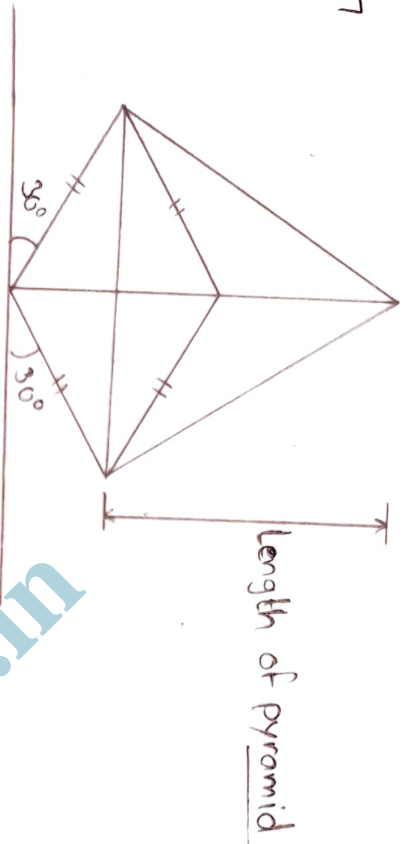

P-17.20

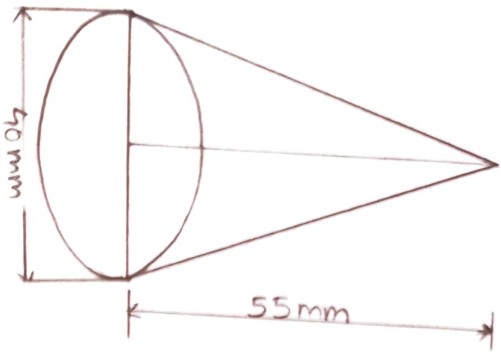

Pentagon —

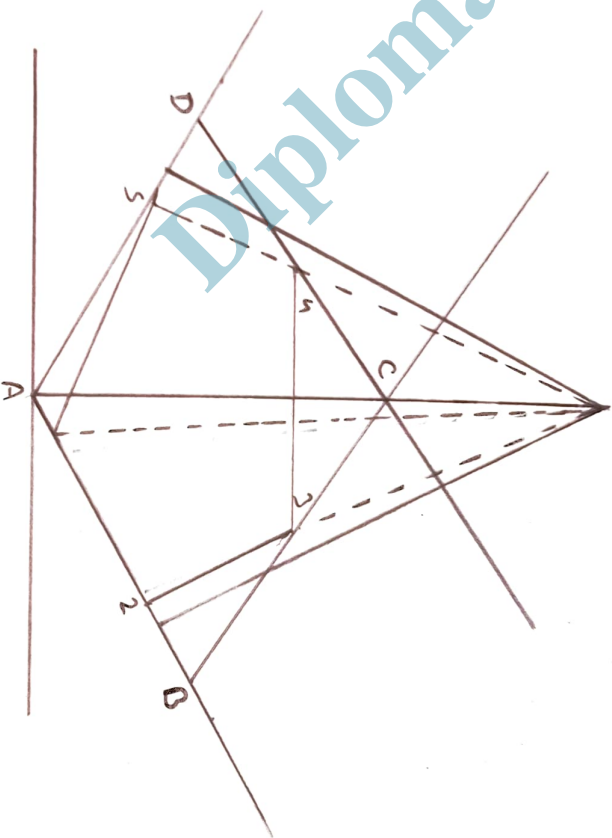
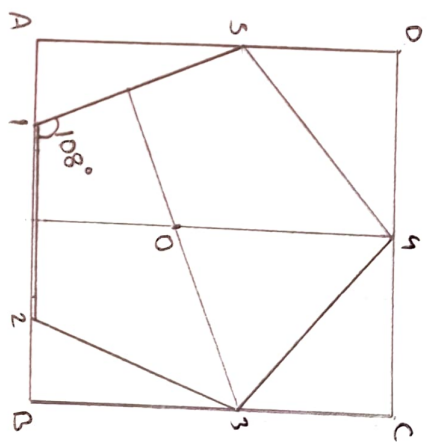

Hexagon

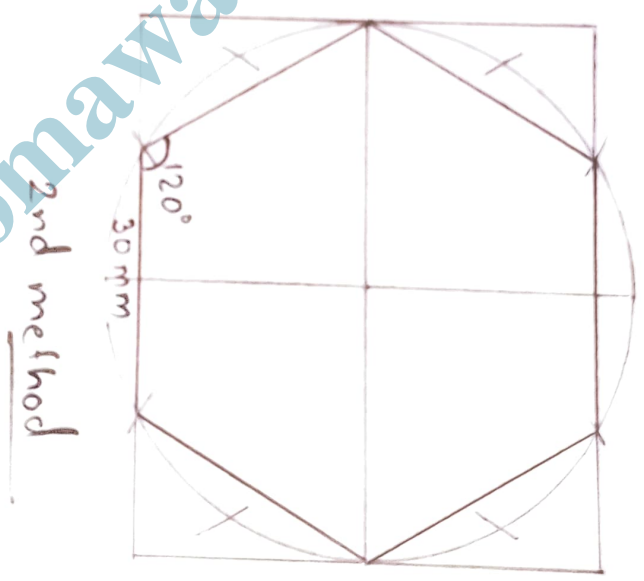
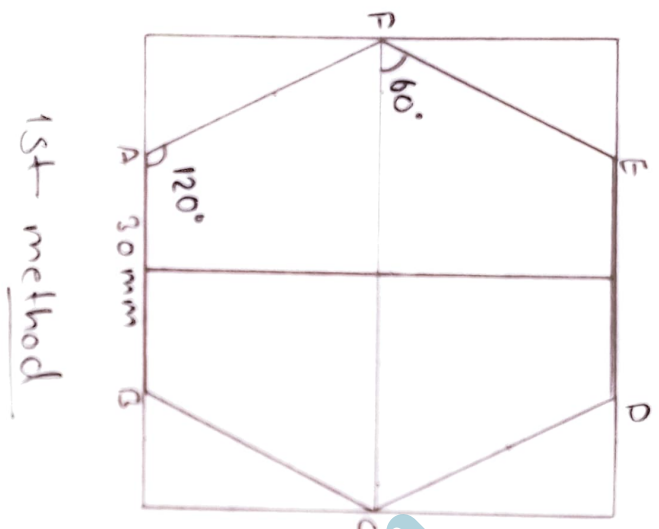

Diplomawallah.in

# Projection of Planes

## Types of plane:-

- 1) AVP - Auxiliary Vertical plane
- 2) AIP - Auxiliary Inclined plane

1) AVP - Plane is perpendicular to H.P. and inclined to V.P. Projection of AVP is called Auxiliary Front view.

2) AIP - AIP is perpendicular to VP and inclined to H.P. Projection on AIP is called Auxiliary top view.

- ① True shape
- ② True length
- ③ Surface angle
- ④ F.V./T.V
- ⑤ AIP

### Side / edge

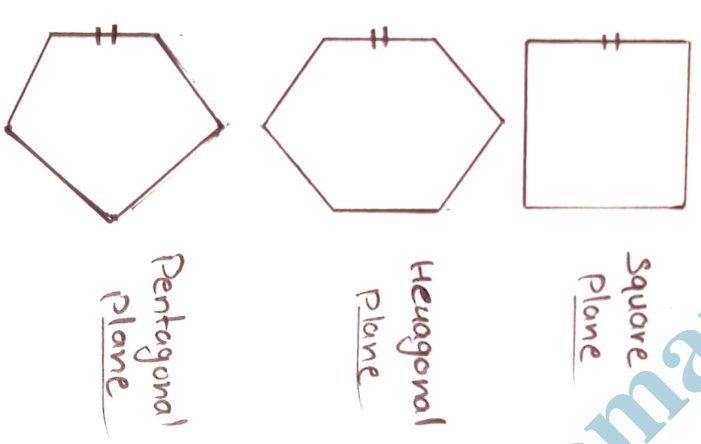

### Corner

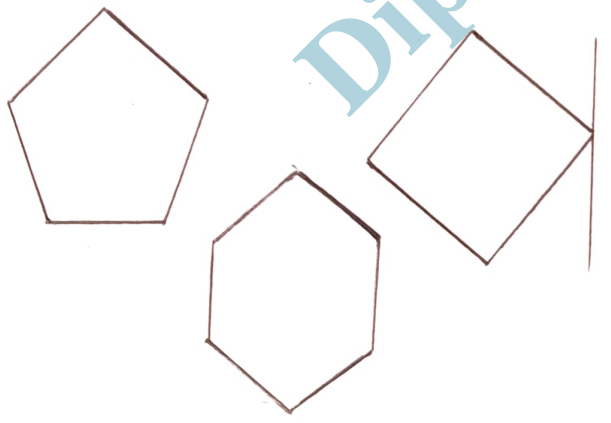

- 1) side in H.P
- 2) Edge in H.P
- 3) Corner in H.P
- 4) Surface Inclined to H.P
- 5) Plane Inclined to H.P
- 6) Edge parallel to H.P

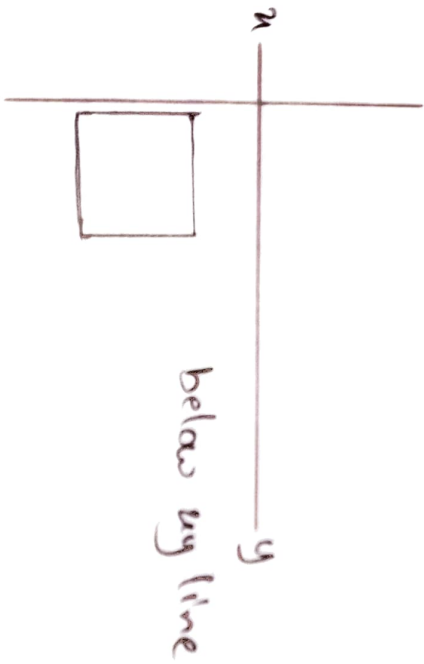

- 1) side in v.p
- 2) edge in v.p
- 3) corner in v.p
- 4) surface Inclined to v.p
- 5) Plane Inclined to v.p
- 6) edge Parallel to v.p

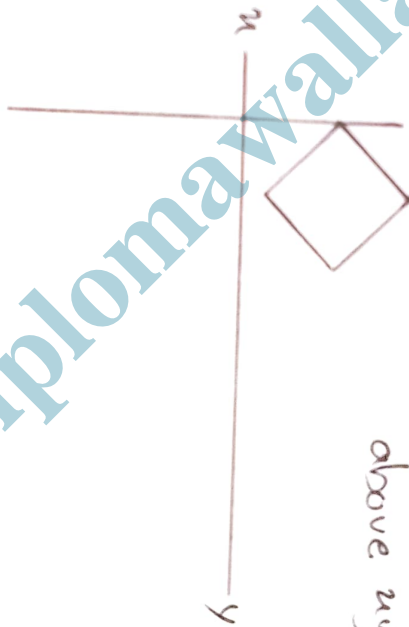

Diplomawallah.in